

4

3

2

1

NOTE: FINISH HEIGHT FROM GROUND TO TOP OF PLASTIC IS 72 1/2"

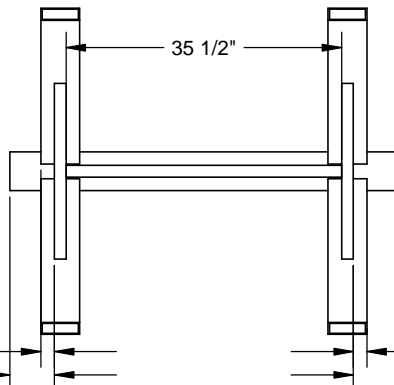
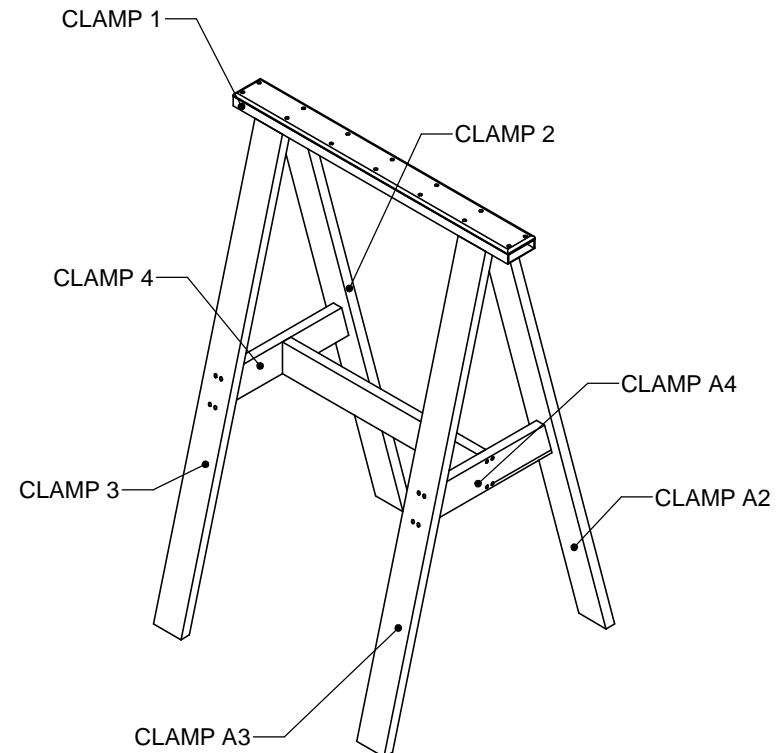
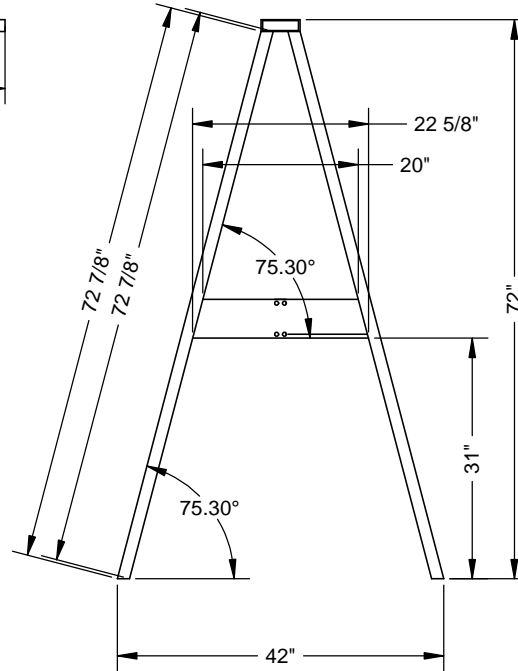
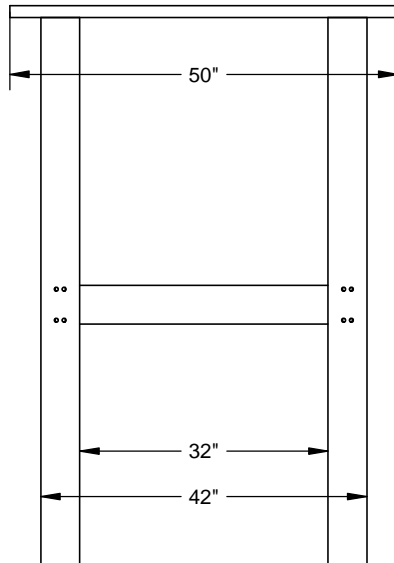
**SAFE WORKING LOAD RATING (PER SAW HORSE):**

- MAX CONCENTRATED LOAD AT MID-SPAN OF TOP RAIL - 1250 lbs
- MAX UNIFORMLY DISTRIBUTED LOAD ACROSS TOP RAIL - 800 lbs/ft

ITEM NO.	QTY.	LENGTH	HEIGHT	DESCRIPTION	MATERIAL
1	1	50"	72"	SAW HORSE	
2	1	50"	5"	TOP PLATE	1/2" BLUE HDPE

UNLESS OTHERWISE SPECIFIED DO NOT SCALE DRAWING INTERPRET DIMENSIONS AND TOLERANCES PER ASME Y14.5M-1994 DIMENSIONS ARE IN INCHES TOLERANCES APPLY AS SHOWN BELOW ± 1/16 INCH ± 1.0 DEGREE UNLESS OTHERWISE NOTED	SolidWorks MAINTAINED DATA CHANGES SHALL BE INCORPORATED ELECTRONICALLY BY THE DESIGN ACTIVITY			885 Rupert St. Waterloo, Ontario Canada N2V 1N7 TEL: (519) 747-1856 (877) 776-5911 FAX: (519) 747-3659 info@sporsystemscorp.com www.sporsystemscorp.com	
	PROPRIETARY NO PART OF THIS DOCUMENT MAY BE REPRODUCED STORED IN A RETRIEVAL SYSTEM OR TRANSMITTED IN ANY FORM WITHOUT THE WRITTEN PERMISSION OF SPORT SYSTEMS UNLIMITED.			TITLE	
THIRD ANGLE PROJECTION	DRAWN BY CHENHOEFFER	DATE Jul 18, 2007	SIZE B	DRAWING NO 2008025-P006	
	CHECKED BY	DATE	SCALE 1:16	MASS 101.714 lbs	REV -
	APPROVED BY	DATE	SHEET 1 OF 1		

4

3

2

1

D

D

C

C

B

B

A

A