

4

3

2

1

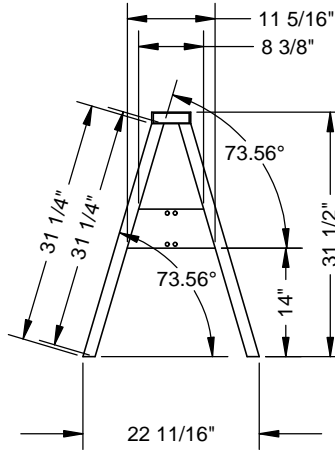
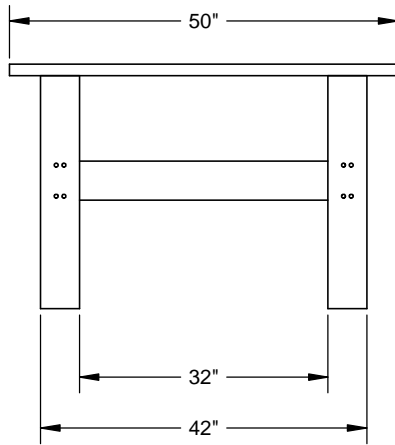

NOTE: FINISH HEIGHT FROM GROUND TO TOP OF PLASTIC IS 32"

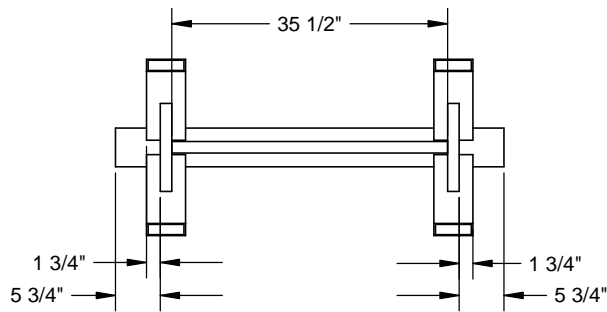
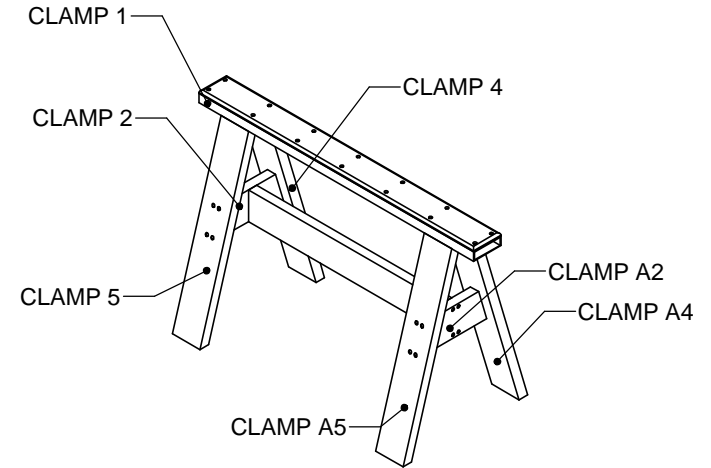
**SAFE WORKING LOAD RATING (PER SAW HORSE):**

- MAX CONCENTRATED LOAD AT MID-SPAN OF TOP RAIL - 1500 lbs
- MAX UNIFORMLY DISTRIBUTED LOAD ACROSS TOP RAIL - 925 lbs/ft

ITEM NO.	QTY.	LENGTH	HEIGHT	DESCRIPTION	MATERIAL
1	1	50"	31 1/2"	SAW HORSE	
2	1	50"	5"	TOP PLATE	1/2" BLUE HDPE

UNLESS OTHERWISE SPECIFIED DO NOT SCALE DRAWING INTERPRET DIMENSIONS AND TOLERANCES PER ASME Y14.5M-1994 DIMENSIONS ARE IN INCHES TOLERANCES APPLY AS SHOWN BELOW $\pm 1/16$ INCH ± 1.0 DEGREE UNLESS OTHERWISE NOTED	SolidWorks MAINTAINED DATA CHANGES SHALL BE INCORPORATED ELECTRONICALLY BY THE DESIGN ACTIVITY PROPRIETARY NO PART OF THIS DOCUMENT MAY BE REPRODUCED STORED IN A RETRIEVAL SYSTEM OR TRANSMITTED IN ANY FORM WITHOUT THE WRITTEN PERMISSION OF SPORT SYSTEMS UNLIMITED.			685 Rupert St. Waterloo, Ontario Canada N2V 1N7 TEL: (519) 747-1856 (877) 776-5311 FAX: (519) 747-3659 info@sporsystems.com www.sporsystems.com	
		SAW HORSE		TITLE	DRAWING NO
THIRD ANGLE PROJECTION 	DRAWN BY CHENHOEFFER	DATE Jul 18, 2007	SIZE B	2008025-P004	-
	CHECKED BY	DATE	SCALE 1:16	MASS 71.203 lbs	SHEET 1 OF 1

ITEM NO.	QTY.	DESCRIPTION	LENGTH
4	4	KE8892	31 3/4"
3	1	KE8892	35 1/2"
2	2	KE8892	11 5/16"
1	1	KE8892	50"

4

3

2

1