

4

3



2

1

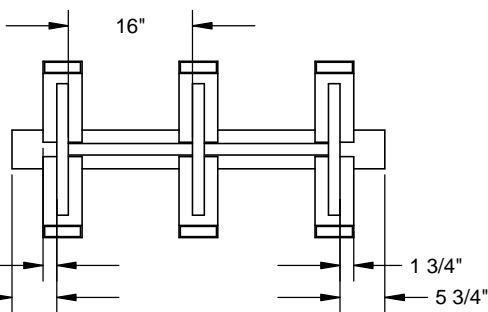
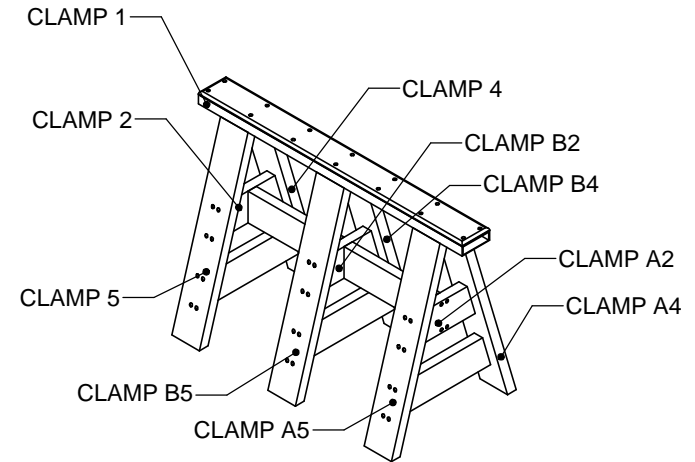
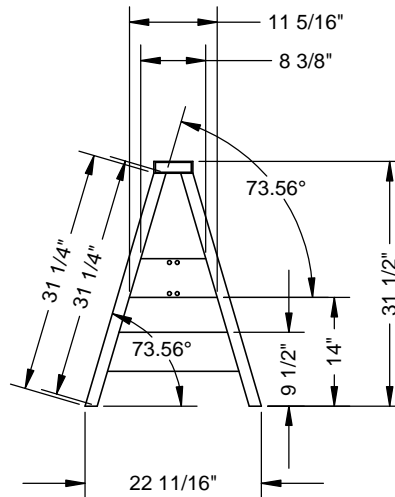
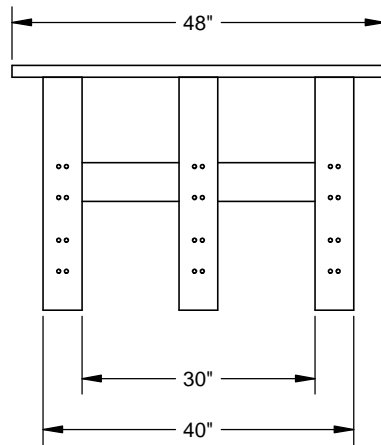
NOTE: FINISH HEIGHT FROM GROUND TO TOP OF PLASTIC IS 32"

**SAFE WORKING LOAD RATING (PER SAW HORSE):**

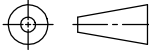
- MAX CONCENTRATED LOAD AT MID-SPAN OF TOP RAIL - 5000 lbs
- MAX UNIFORMLY DISTRIBUTED LOAD ACROSS TOP RAIL - 4000 lbs/ft

ITEM NO.	QTY.	DESCRIPTION	LENGTH	ITEM NO.	QTY.	LENGTH	HEIGHT	DESCRIPTION	MATERIAL										
4	2	KE8892	31 3/4"	1	1	48"	31 1/2"	SAW HORSE											
3	2	KE8892	16"	2	1	48"	5"	TOP PLATE	1/2" BLUE HDPE										
2	2	KE8892	11 5/16"	UNLESS OTHERWISE SPECIFIED DO NOT SCALE DRAWING INTERPRET DIMENSIONS AND TOLERANCES PER ASME Y14.5M-1994 DIMENSIONS ARE IN INCHES TOLERANCES APPLY AS SHOWN BELOW ± 1/16 INCH ± 1.0 DEGREE UNLESS OTHERWISE NOTED THIRD ANGLE PROJECTION 						SolidWorks MAINTAINED DATA CHANGES SHALL BE INCORPORATED ELECTRONICALLY BY THE DESIGN ACTIVITY <b>PROPRIETARY</b> NO PART OF THIS DOCUMENT MAY BE REPRODUCED STORED IN A RETRIEVAL SYSTEM OR TRANSMITTED IN ANY FORM WITHOUT THE WRITTEN PERMISSION OF SPORT SYSTEMS UNLIMITED. CUSTOMER PROJECT DRAWN BY CHENHOEFFER CHECKED BY DATE APPROVED BY DATE DATE Jul 18, 2007 DATE DATE		 685 Rupert St. Waterloo, Ontario Canada N2V 1N7 TEL: (519) 747-1856 (877) 776-5311 FAX: (519) 747-3659 info@sporsystems.com www.sporsystems.com							
1	1	KE8892	48"											<b>SAW HORSE</b>		TITLE			
5	2	KE8892	31 3/4"														SIZE B	DRAWING NO. 2008025-P008	REV -
6	3	KE8892	16 15/16"														SCALE 1:16	MASS 87.987 lbs	SHEET 1 OF 1
7	1	KE8892	11 5/16"																
8	2	KE8892	31 3/4"																

4

3

2

1